

# LUX 20 RGB

Mounting instructions  
Instructions de montage  
Betriebsanweisung  
Istruzioni di montaggio

Sanded chromed brass /  
Laiton chromé satiné /  
Messing matt /  
Ottone cromato satinato:  
11702103 - RGB - 25°  
11702303 - RGB - 10°

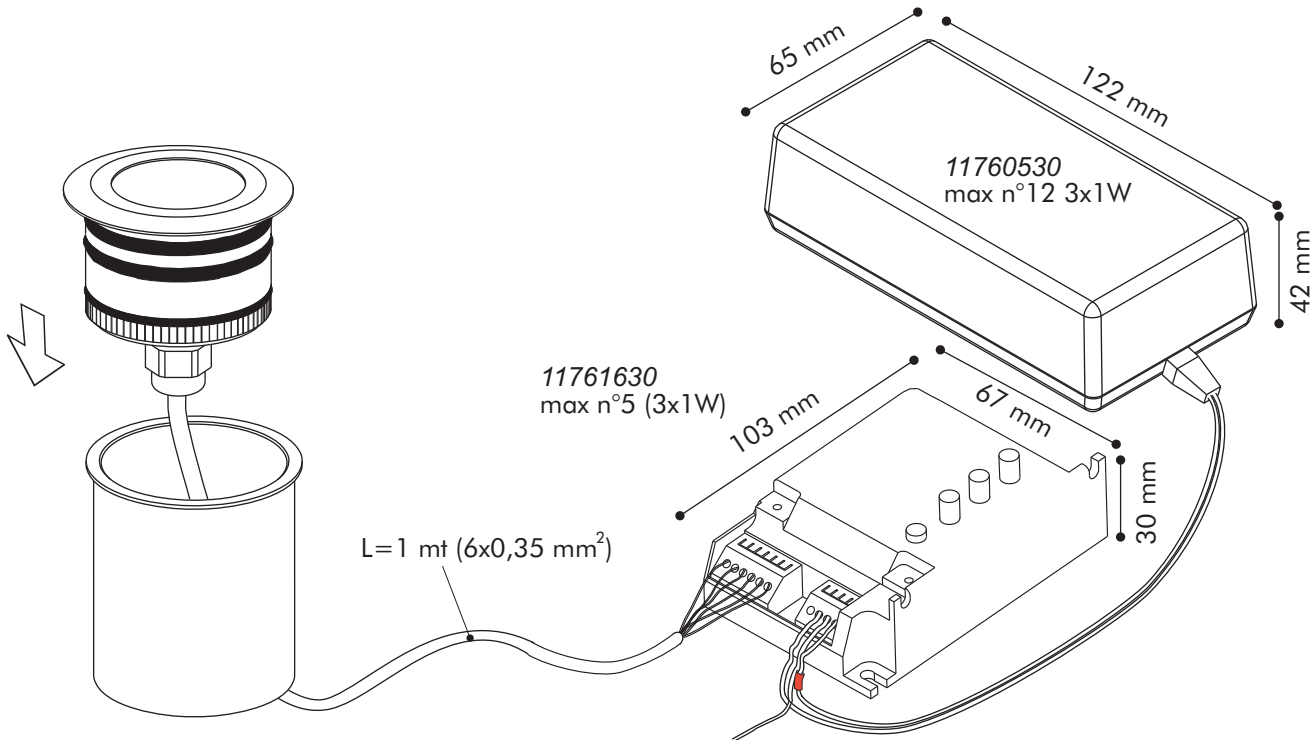

**CAUTION:** Connect the fitting to the power supply only after connecting all Led to the LED gear.  
**ATTENTION:** Brancher le courant seulement apres avoir connecter tous les Led au transformateur.  
**ACHTUNG:** Verbinden Sie die Anlage nur nach alle Leds an der Speiser verbindet sind.  
**ATTENZIONE:** Dare tensione all'impianto solo dopo aver collegato tutti i LED all'alimentatore.

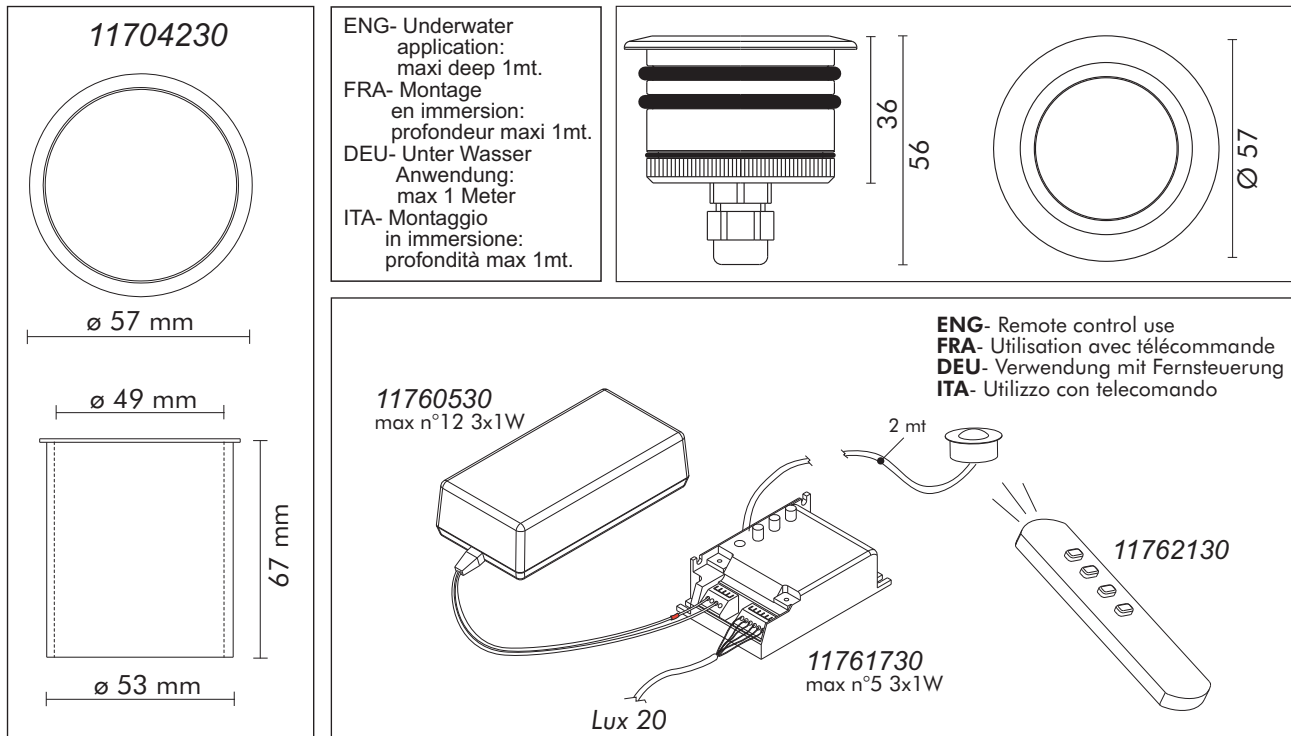



**LUX 20 RGB**  
Mounting instructions  
Instructions de montage  
Betriebsanweisung  
Istruzioni di montaggio

**IP67-68 application**

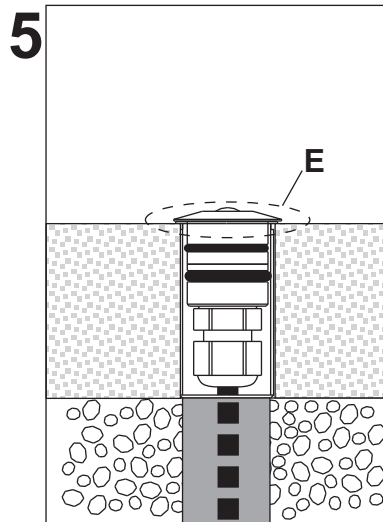
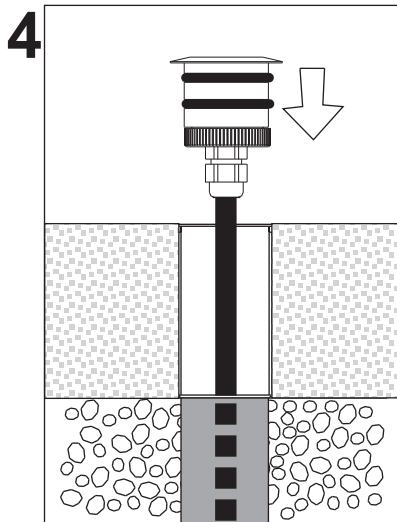
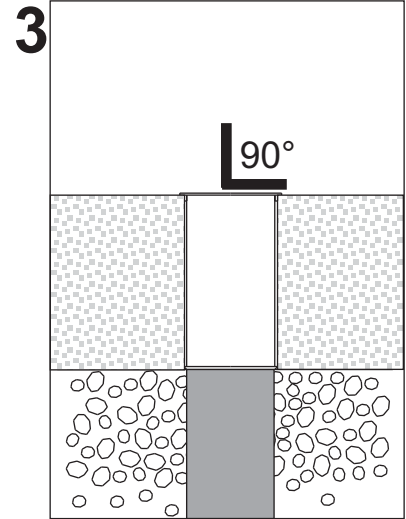
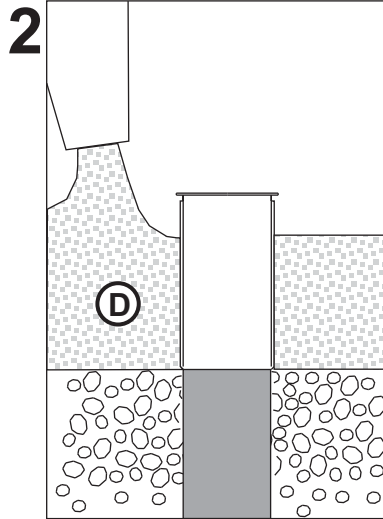
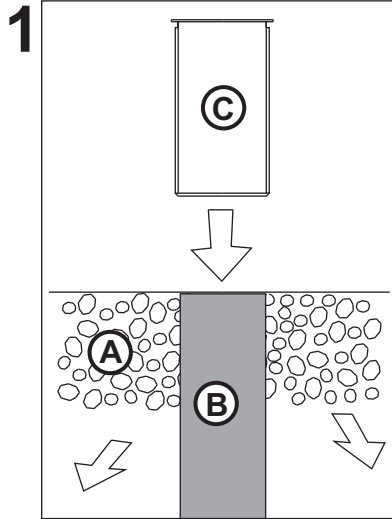

- (A) -drainage  
-drainage  
-drainage  
-drenaggio
- (B) -tube for cables  
-tube pour cablage  
-rohr Verkabelung  
-tubo per cablaggio
- (C) -boxskill (ABS)  
-boitier (ABS)  
-boxskill Gehäuse (ABS)  
-cassaforma (ABS)
- (D) -concrete  
-ciment  
-Zement  
-cemento
- (E) -for underwater use we suggest to apply a silicone layer between boxskill and the spot.  
-pour usage en immersion il est conseillé d'appliquer une couche de silicone entre le boitier et le spot.  
-für den einsatz unter Wasser kleben sie eine schicht von Silikon zwischen Gehäuse und Spotlight.  
-per utilizzo in immersione è consigliabile applicare uno strato di silicone tra cassaforma e faretto.



**-Make the wiring using a system that guarantees at least the IP67 degree protection.**

**-Effectuer le cablage en utilisant un système garantissant au moins l'indice IP67.**

**-Machen Sie eine Verdrahtung mit einem System das gewährleistet mindestens IP67.**

**-Effettuare il cablaggio usando un sistema che garantisca almeno il grado IP67.**



**-Installation should be carried out by a suitable qualified installer.**

**-L'installation doit être effectuée par un personnel qualifié.**

**-Die Intallation muss von qualifiziertem Personal durchgeführt werden.**

**-L'installazione deve essere fatta da personale qualificato.**



**-Periodically clean the frontal part of the spot. Do not use acid substances.**

**-Nettoyer périodiquement la surface antérieure du spot. Ne pas utiliser les produits à base d'acide.**

**-Regelmäßige Reinigung der vorderseite des Spots. Verwenden sie keine säurehaltigen Reinigungsmitteln.**

**-Pulire periodicamente la superficie frontale del faretto. Non utilizzare detersivi a base acida.**

**ENG- Fixation of the spring  
FRA- Fixation des clips  
DEU- Befestigung Sie der Springfeder  
ITA- Fissaggio molle per incasso**

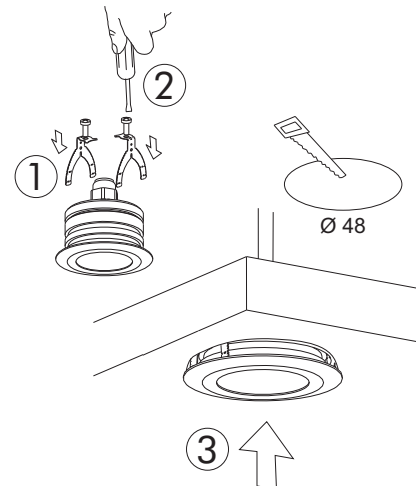



# LUX SPOTS

## DMX control 24V DC

Example of connection  
Exemple de connection

- N** Led gear / Alimentation  
**11760530**  
Up to 2 SLAVE DMX (Up to 12 spots LED 3x1W) /  
Jasqu'à 2 SLAVE DMX (12 spots LED 3x1W)
- Master DMX**  
Master / Console DMX  
**11761830**  
117x80x50
- S** Slave DMX  
**11762030**  
Up to 6 spots LED 3x1W (24V feeding) /  
Jasqu'à 6 spots LED 3x1W (alimentation 24V)  
120x72x35

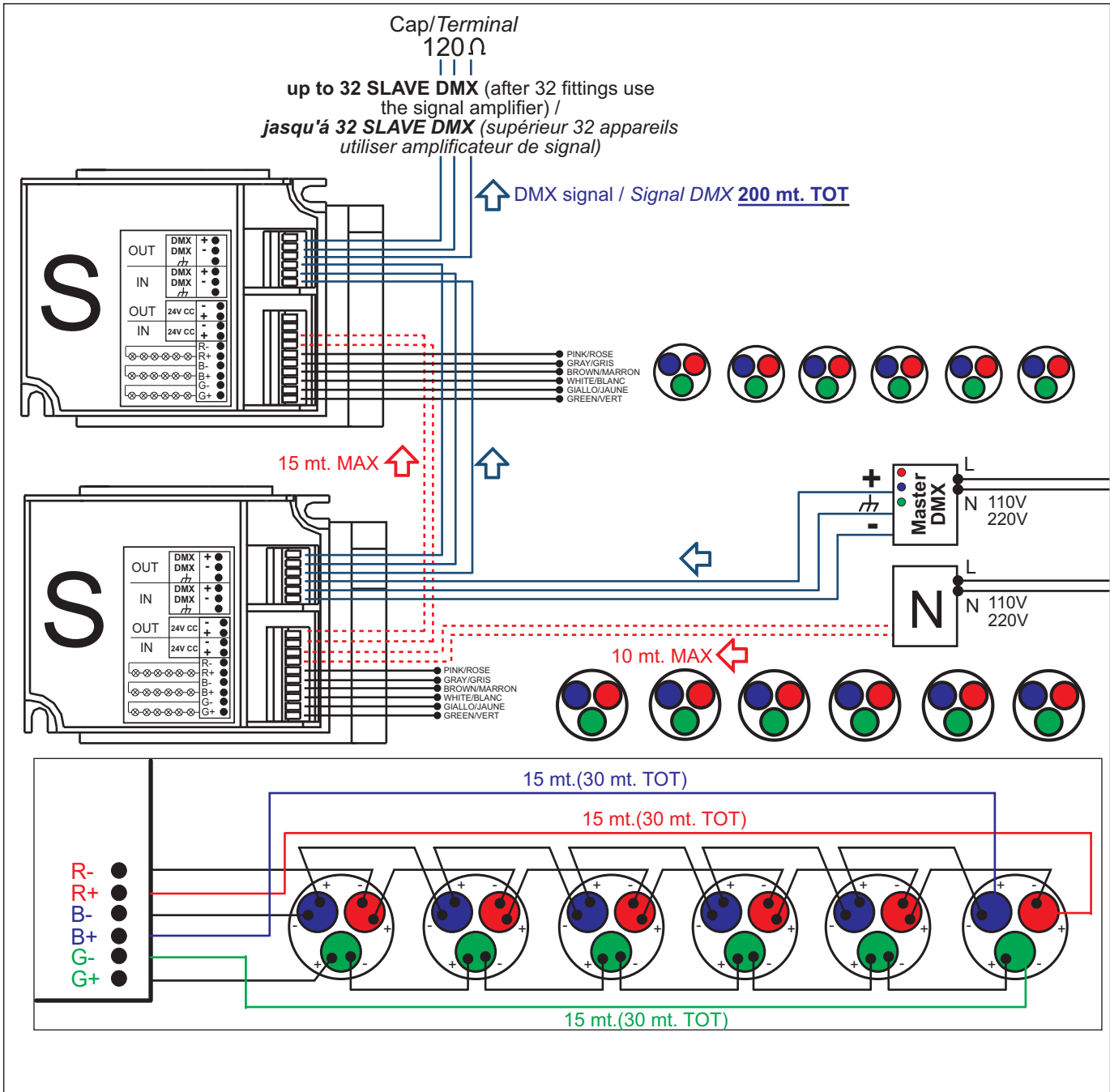
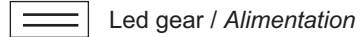
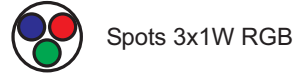



STRENG VERTRAULICH  
DOCUMENTO CONFIDENZIALE

**LUX SPOTS**  
**DMX control 24V DC**  
Verbindungsbeispiele  
Schema di collegamento



Einspeiser / Alimentatore  
**11760530**  
Bis 2 SLAVE DM X (bis 12 spots LED 3x1W) /  
Fino a 2 SLAVE DM X(12 faretti LED 3x1W)



Console DMX  
**11761830**  
117x80x50



Slave DMX  
**11762030**  
Bis 6 spots LED 3x1W (24V einspeiser) /  
Fino a 6 faretti LED 3x1W (alimentazione 24V)  
120x72x35



Spots 3x1W RGB / Faretto 3x1W RGB



Einspeiser / Alimentazione



Einspeiser 24V / Alimentazione 24V



DMX signal / Segnale DMX **200 mt. TOT**

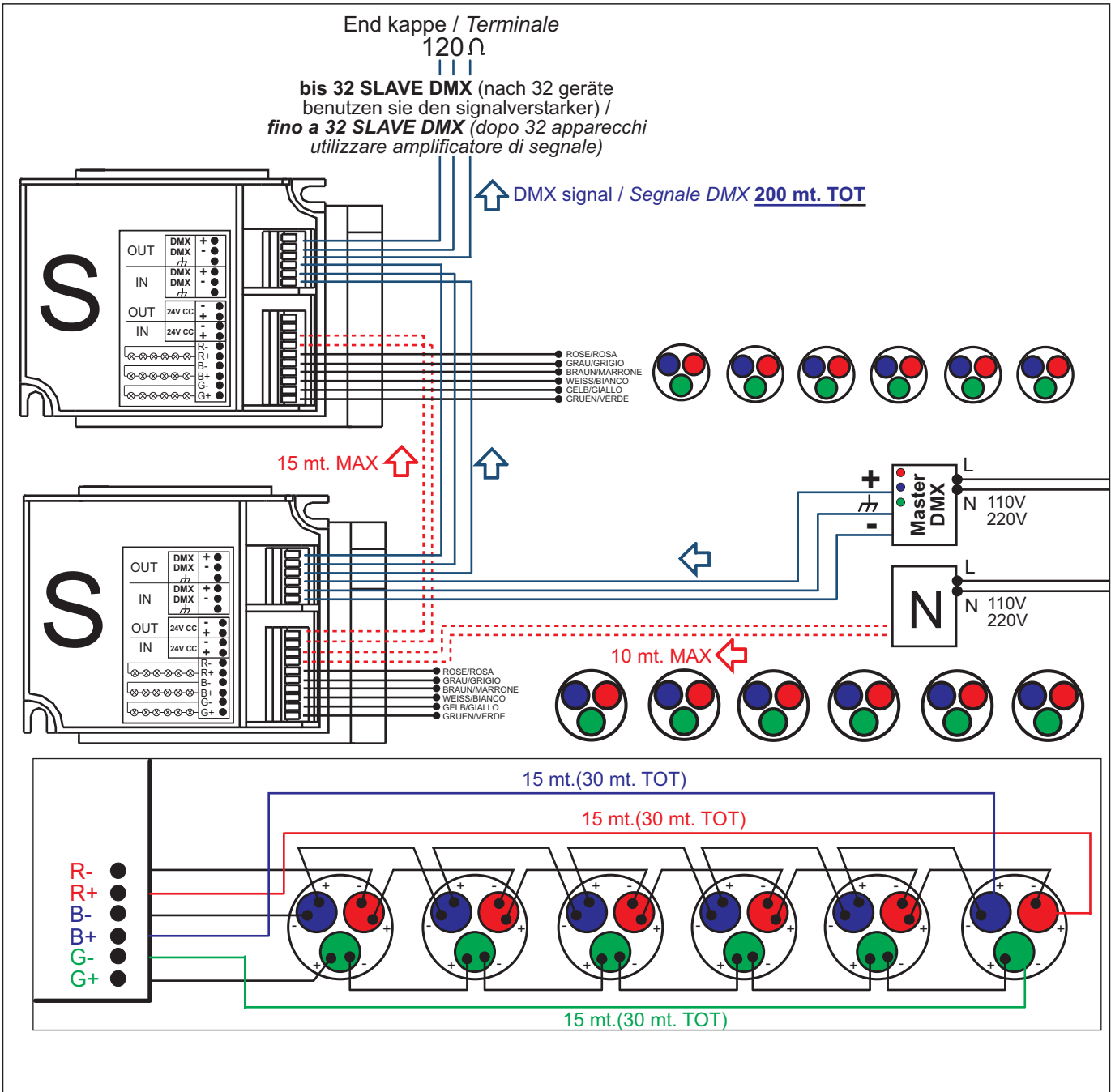



**LUX SPOTS**  
**DMX control 12V DC**  
**for water immersion**  
*pour utilisation en immersion*

**M**

Led gear / Alimentation  
**11761230**

**Master DMX**

Master / Console DMX  
**11761830**  
117x80x50

**S**

Slave DMX  
**11762030**  
Up to 3 spots LED 3x1W (12V feeding) /  
Jasqu'à 3 spots LED 3x1W (alimentation 12V)  
120x72x35



Spots 3x1W RGB



Led gear / Alimentation



Led gear 12V / Alimentation 12V



DMX signal / Signal DMX **200 mt. TOT**

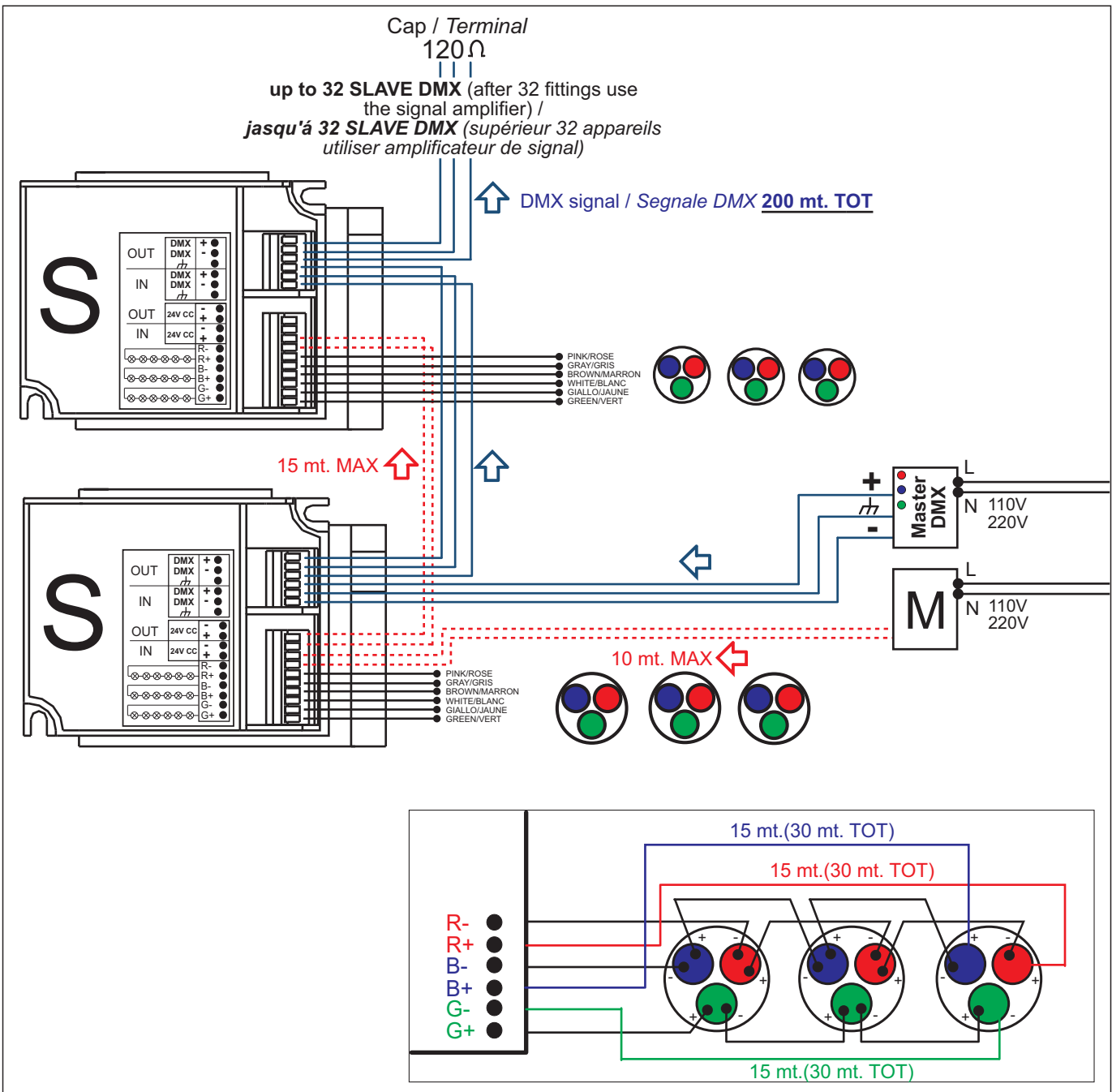



**LUX SPOTS**  
**DMX control 12V DC**  
für unter wasser  
per uso in immersione

**M**

Einspeiser / Alimentatore  
11761230

**Master DMX**

Console DMX  
11761830  
117x80x50

**S**

Slave DMX  
11762030  
Bis 3 spots LED 3x1W (12V einspeiser) /  
Fino a 3 faretti LED 3x1W (alimentazione 12V)  
120x72x35



Spots 3x1W RGB / Faretti 3x1W RGB



Einspeiser / Alimentazione



Einspeiser 12V / Alimentazione 12V



DMX signal / Segnale DMX 200 mt. TOT

