

LUX 12 WALK OVER

Mounting instructions
Instructions de montage
Betriebsanweisung
Istruzioni di montaggio

Sanded chromed brass /
Laiton chromé satiné /
Messing matt /
Ottone cromato satinato:
11703103 - white/blanc/weiss/bianco

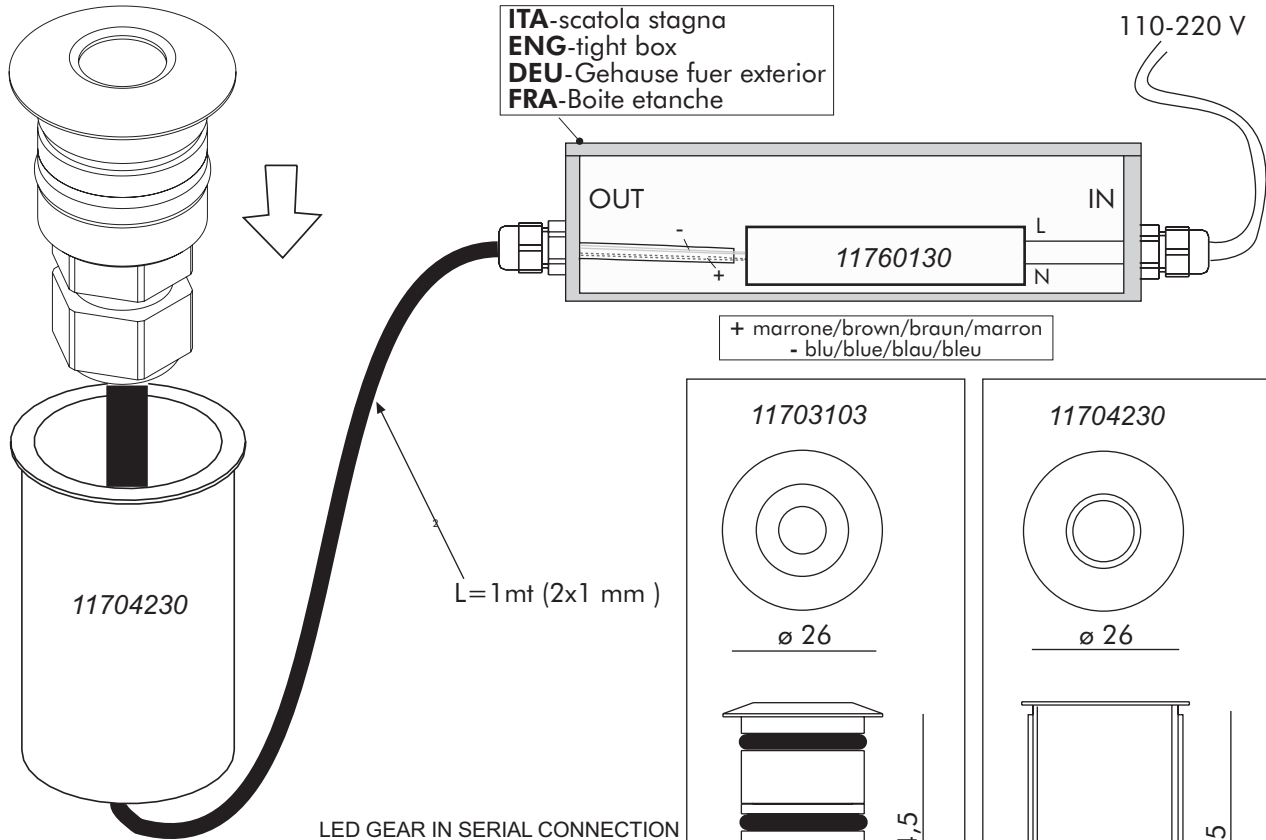

LED GEAR IN SERIAL CONNECTION
ALIMENTATION EN SERIE
SPEISER IN SERIEN-VERBINDUNG
ALIMENTATORI IN SERIE

11760030	n° 1 Lux 12
11760130	(2)n° 3 Lux 12
11760230	(5)n° 8 Lux 12
11760330	(8)n° 12 Lux 12
11762230	(8)n° 12 Lux 12

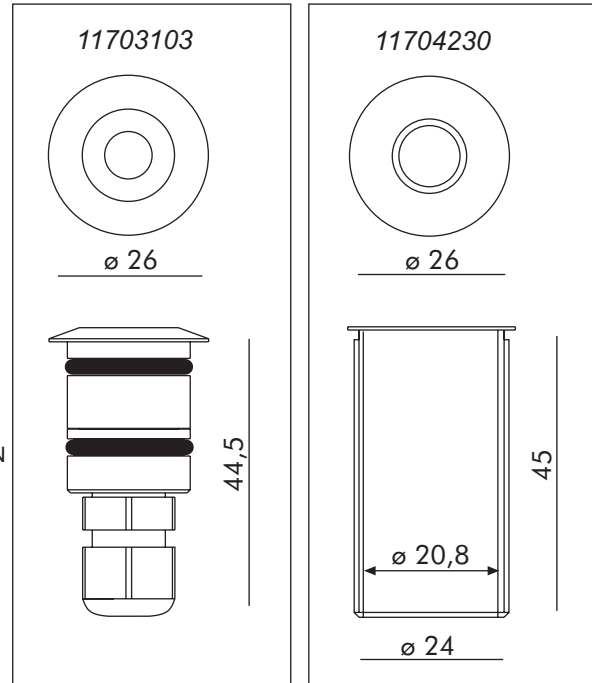

ENG-Underwater application:
maxi deep 1mt.
FRA-Montage en immersion:
profondeur maxi 1mt.
DEU-Unter Wasser Anwendung:
max 1 Meter
ITA-Montaggio in immersione:
profondità max 1mt.

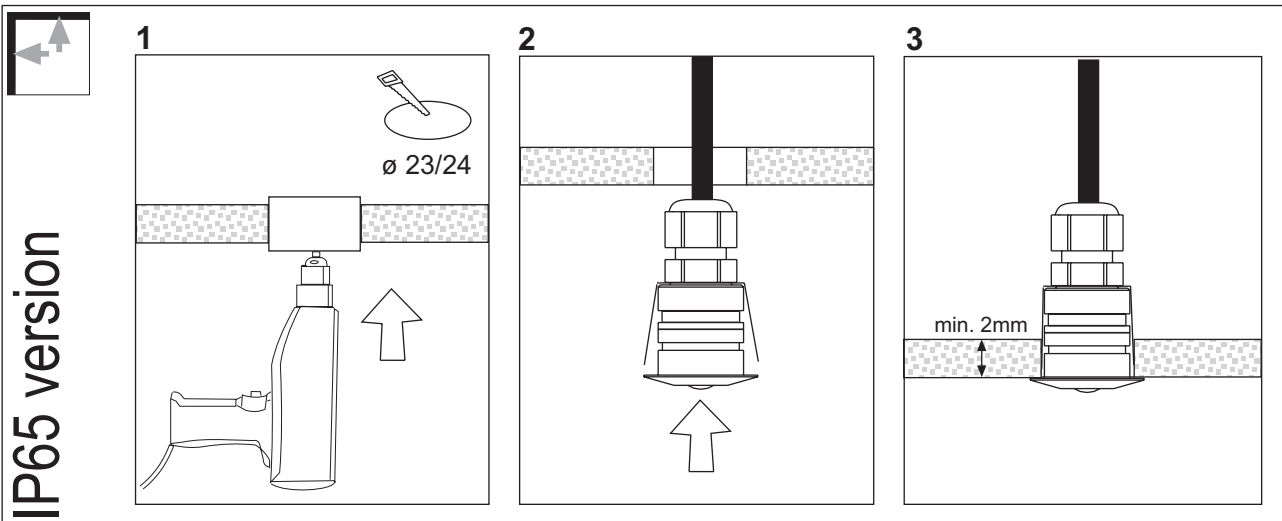

LUX 12 WALK OVER

Mounting instructions
Instructions de montage
Betriebsanweisung
Istruzioni di montaggio

IP67-68 application

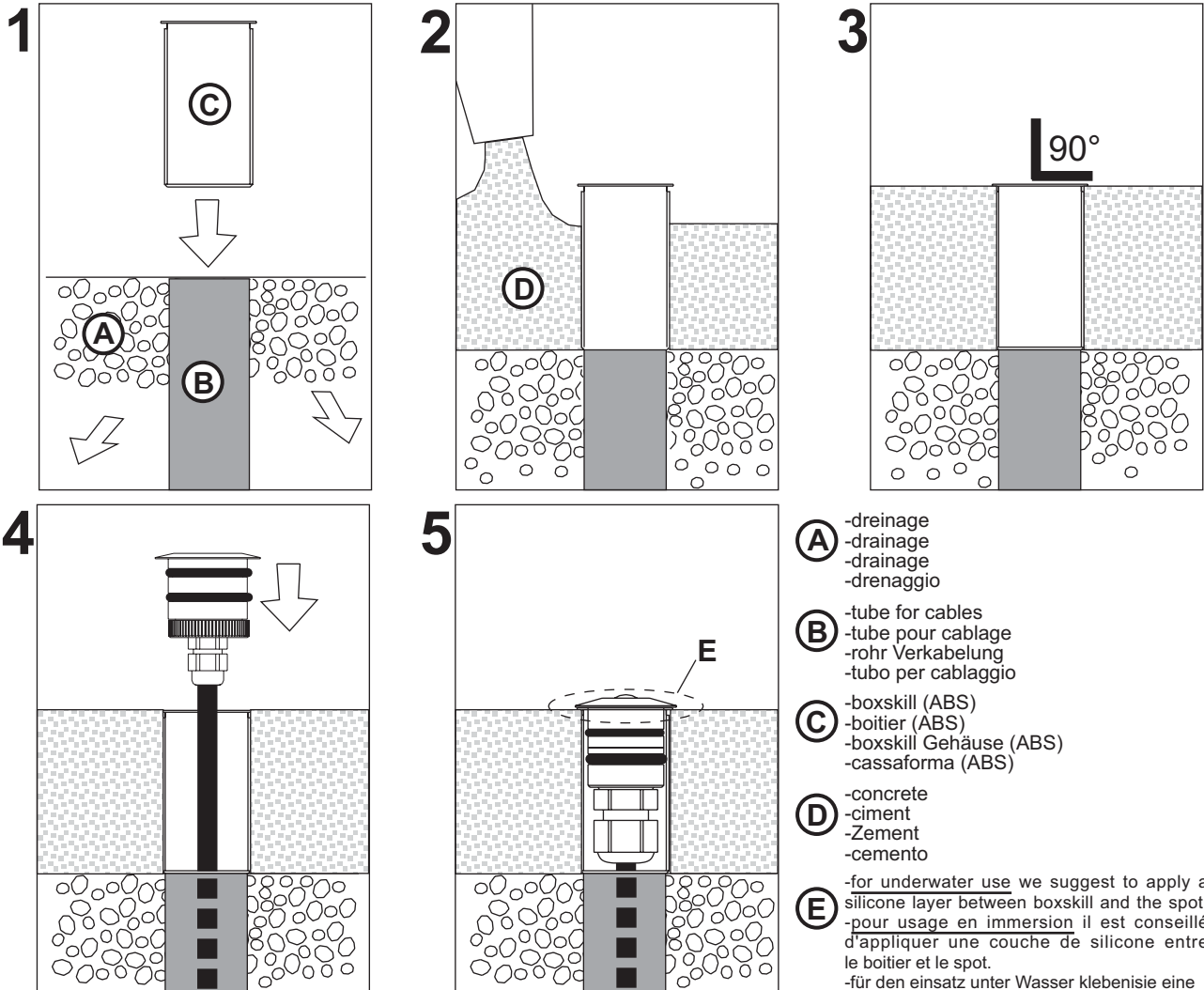

- (A) -drainage
-drainage
-drainage
-drenaggio
- (B) -tube for cables
-tube pour cablage
-rohr Verkabelung
-tubo per cablaggio
- (C) -boxskill (ABS)
-boitier (ABS)
-boxskill Gehäuse (ABS)
-cassaforma (ABS)
- (D) -concrete
-ciment
-Zement
-cemento
- (E) -for underwater use we suggest to apply a silicone layer between boxskill and the spot.
-pour usage en immersion il est conseillé d'appliquer une couche de silicone entre le boitier et le spot.
-für den einsatz unter Wasser kleben sie eine schicht von Silikon zwischen Gehäuse und Spotlight.
-per utilizzo in immersione è consigliabile applicare uno strato di silicone tra cassaforma e faretto.



-Make the wiring using a system that guarantees at least the IP67 degree protection.

-Effectuer le cablage en utilisant un système garantissant au moins l'indice IP67.

-Machen Sie eine Verdrahtung mit einem System das gewährleistet mindestens IP67.

-Effettuare il cablaggio usando un sistema che garantisca almeno il grado IP67.



-Installation should be carried out by a suitable qualified installer.

-L'installation doit être effectuée par un personnel qualifié.

-Die Intallation muss von qualifiziertem Personal durchgeführt werden.

-L'installazione deve essere fatta da personale qualificato.



-Periodically clean the frontal part of the spot. Do not use acid substances.

-Nettoyer périodiquement la surface antérieure du spot. Ne pas utiliser les produits à base d'acide.

-Regelmäßige Reinigung der vorderseite des Spots. Verwenden sie keine säurehaltigen Reinigungsmitteln.

-Pulire periodicamente la superficie frontale del faretto. Non utilizzare detersivi a base acida.

ENG- EXAMPLE OF CONNECTION
(serial connection)
FRA- EXEMPLE DE CONNECTION
(connection en serie)
DEU- VERBINDUNGSBEISPIELE
(serien-Verbindung)
ITA- ESEMPIO DI COLLEGAMENTO
(connessione in serie)

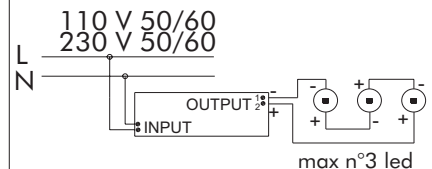

11760130
350mA