

LUX 10 R

Mounting instructions
 Instructions de montage
 Betriebsanweisung
 Istruzioni di montaggio

11703303 - white/blanc/weiss/bianco - 10°
 11703403 - white/blanc/weiss/bianco - 25°
 11703503 - white/blanc/weiss/bianco - 40°

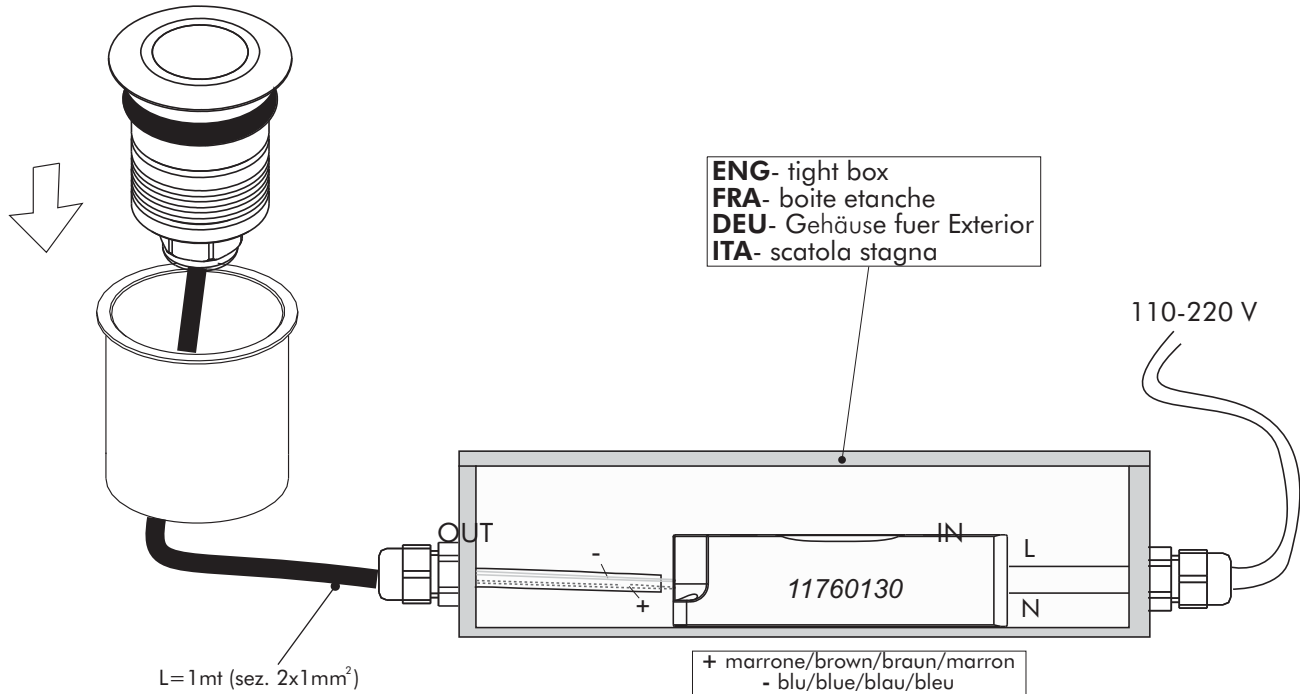

ENG -In presence of atmospheres or materials I corroded to you to consider the prescription of the **IEC 364-7**
FRA - En présence des atmosphères ou des matériaux j'ai corrodé à vous pour considérer la prescription du **IEC 364-7**
DEU - In Gegenwart von korrosiven Umgebungen oder Materials unter Berücksichtigung der Anforderungen der **IEC 364-7**
ITA - In presenza di ambienti o materiali corrosivi considerare le prescrizioni della **IEC 364-7**

SAFETY LED GEAR
ALIMENTATION DE SECURITE
SICHERUNG SPEISER
ALIMENTATORI DI SICUREZZA

11760130	n° 1 Lux 10 R
11760230	n° 2 Lux 10 R
11760330	n° 4 Lux 10 R
11762230	n° 4 Lux 10 R

CAUTION: Connect the fitting to the power supply only after connecting all Led to the LED gear.
ATTENTION: Brancher le courant seulement apres avoir connecter tous les Led au transformateur.
ACHTUNG: Verbinden Sie die Anlage nur nach alle Leds an der Speiser verbindet sind.
ATTENZIONE: Dare tensione all'impianto solo dopo aver collegato tutti i LED all'alimentatore.

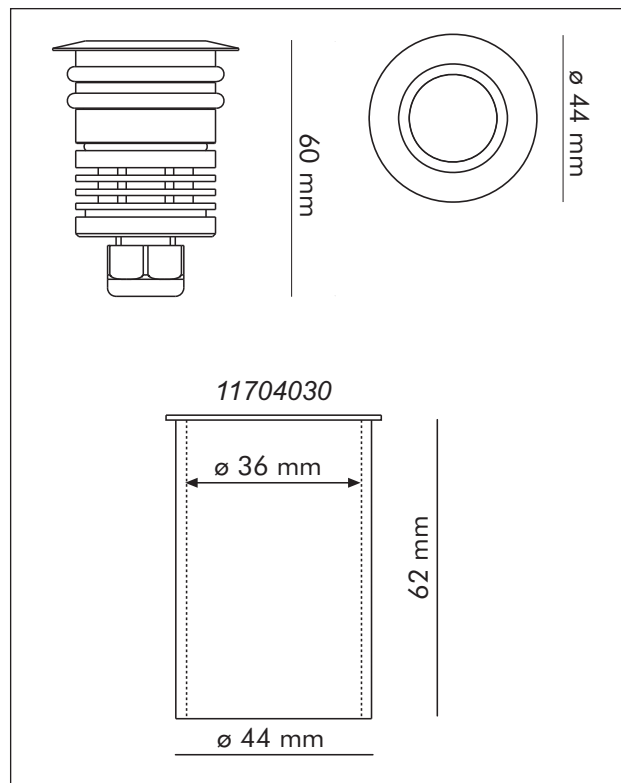
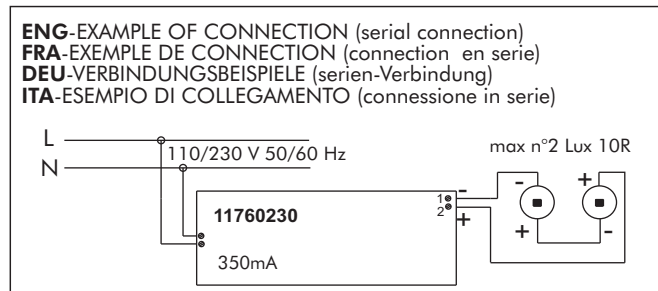

LUX 10 R

Mounting instructions
Instructions de montage
Betriebsanweisung
Istruzioni di montaggio

IP67 application

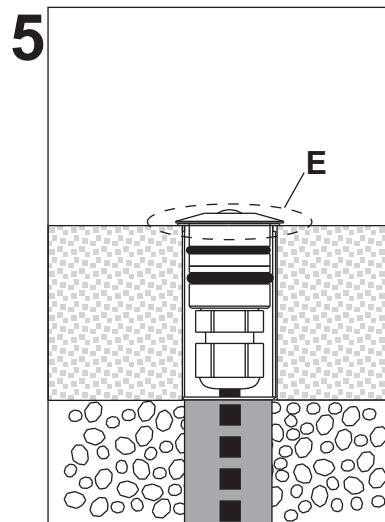
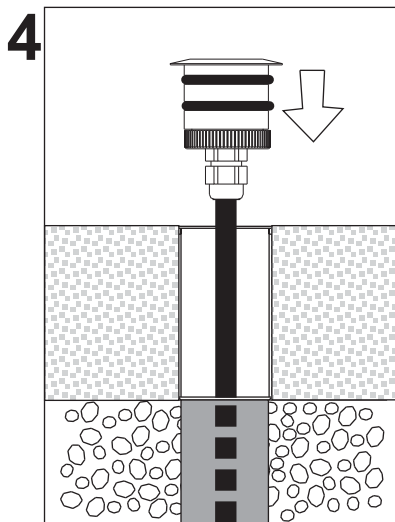
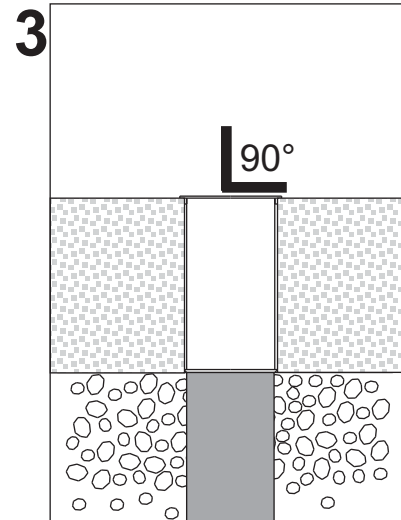
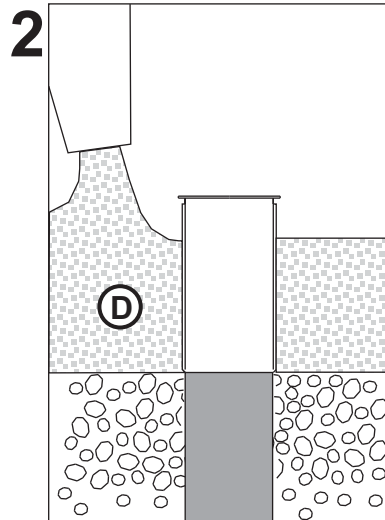
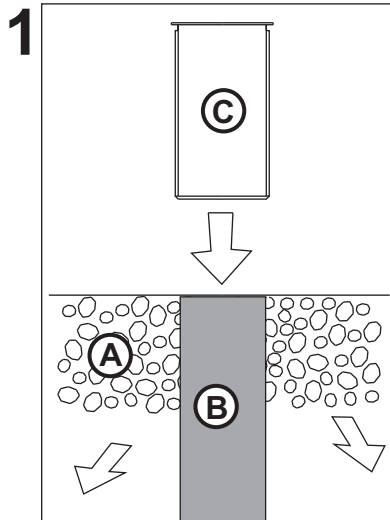

- (A) -drainage
-drainage
-drainage
-drenaggio
- (B) -tube for cables
-tube pour cablage
-rohr Verkabelung
-tubo per cablaggio
- (C) -boxskill (ABS)
-boitier (ABS)
-boxskill Gehäuse (ABS)
-cassaforma (ABS)
- (D) -concrete
-ciment
-Zement
-cemento
- (E) -for underwater use we suggest to apply a silicone layer between boxskill and the spot.
-pour usage en immersion il est conseillé d'appliquer une couche de silicone entre le boitier et le spot.
-für den einsatz unter Wasser kleben sie eine schicht von Silikon zwischen Gehäuse und Spotlight.
-per utilizzo in immersione è consigliabile applicare uno strato di silicone tra cassaforma e faretto.



- Make the wiring using a system that guarantees at least the IP67 degree protection.
- Effectuer le cablage en utilisant un système garantissant au moins l'indice IP67.
- Machen Sie eine Verdrahtung mit einem System das gewährleistet mindestens IP67.
- Effettuare il cablaggio usando un sistema che garantisca almeno il grado IP67.



- Installation should be carried out by a suitable qualified installer.
- L'installation doit être effectuée par un personnel qualifié.
- Die Intallation muss von qualifiziertem Personal durchgeführt werden.
- L'installazione deve essere fatta da personale qualificato.



- Periodically clean the frontal part of the spot. Do not use acid substances.
- Nettoyer périodiquement la surface antérieure du spot. Ne pas utiliser les produits à base d'acide.
- Regelmäßige Reinigung der vorderseite des Spots. Verwenden Sie keine säurehaltigen Reinigungsmitteln.
- Pulire periodicamente la superficie frontale del faretto. Non utilizzare detersivi a base acida.